

YBS Insulation

HIGH QUALITY PRODUCTS FOR THE BUILDING INDUSTRY

CI/SfB (47) Rn7



CERTIFICATE NUMBER 033/96

Therma-Close

GENERAL PURPOSE INSULATED CAVITY CLOSER



Cavity closer incorporating DPC

NHBC Approved

Fully Certified

Million's of linear metres supplied

CFC/HCFC Free - Environmentally Friendly

Waterproofs, insulates, self locating

Manufactured in UK and made to a Quality System meeting the requirements of BS EN ISO 9002



www.ybsinsulation.com

One of the most competitive, user friendly insulated cavity closer in the marketplace

Therma-Close is manufactured as an all-in-one cavity closer system, comprising of a D.P.C. with an integral insulation and a unique positioning clip, making it one of the most user friendly insulated cavity closer systems, in the marketplace. It is designed to be used in jamb, cill and threshold of windows and doors respectively to provide a total solution to the cold bridging problem associated with openings in traditional cavity construction. A greater awareness of thermal efficiency has lead to the reduction of the 'U' value requirements of the structure, as emphasised in the recent revision to the Building Regulations. **Therma-Close** is designed to offer the perfect solution for the specifier to satisfy this requirement.

Therma-Close

GENERAL PURPOSE INSULATED CAVITY CLOSER

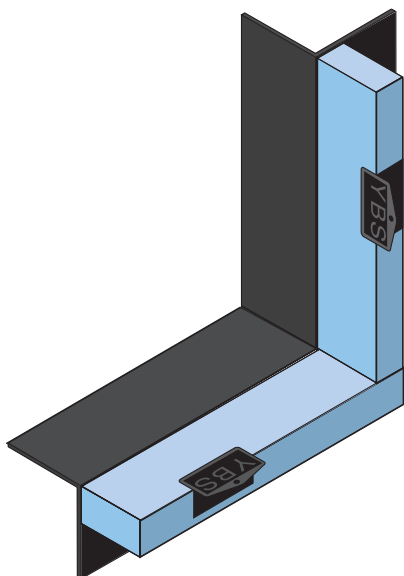

Horizontal/vertical **Therma-Close** junction.

Vertical

- If used in a horizontal and vertical situation 100mm of the insulation should be cut/ trowelled off the dpc prior to the commencement of the installation.
- The exposed dpc should be lapped onto the horizontal dpc, the exposed edge of the installation should then be butted as tightly as possible onto the top of the horizontally placed **Therma-Close**.
- **Therma-Close** can be built-in as the work progresses.
- Alternatively **Therma-Close** can be tacked on the side of the window frame, if the window is to be built-in.
- **Therma-Close** should be positioned with the dpc facing outwards.
- The inner face of the reveal to be dry-lined.

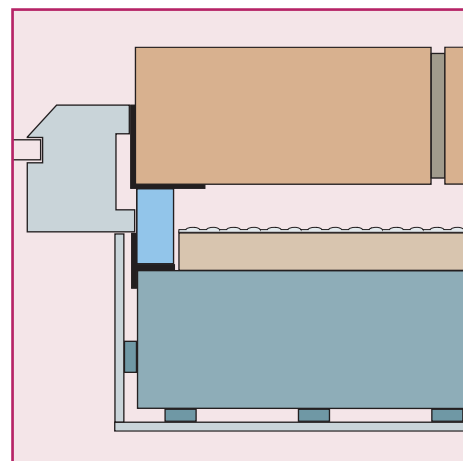

Jamb reveal detail.
Therma-Close in vertical application.

Horizontal

- **Therma-Close** should be positioned at the cill/threshold being held in place by the locating clips.
- The protruding dpc should be lapped beneath the cill/threshold.
- **Therma-Close** should be positioned with the dpc facing outwards.

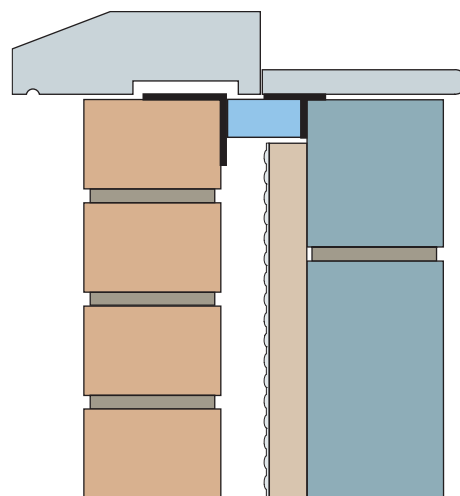

Therma-Close cill detail.



COMPREHENSIVE FIXING DETAILS ARE AVAILABLE UPON REQUEST

Technical Data

ALL FINISHED INSULATION SIZES HAVE A TOLERANCE OF -4MM +0MM

Cavity Size	Length	Insulation Depth	Insulation Width
50mm	2.5m	38mm	50mm
65mm	2.5m	38mm	65mm
75mm	2.5m	38mm	75mm
85mm	2.5m	38mm	85mm
100mm	2.5m	38mm	100mm

Performance Test Data of DPC

DPC to BS B56515 1984 High Performance Polyethylene DPC

Performance Test Data of Insulation

X.P.S. (Extruded Polystyrene to European Standard EN 13164)

Thermal Conductivity 0.029 W/mK

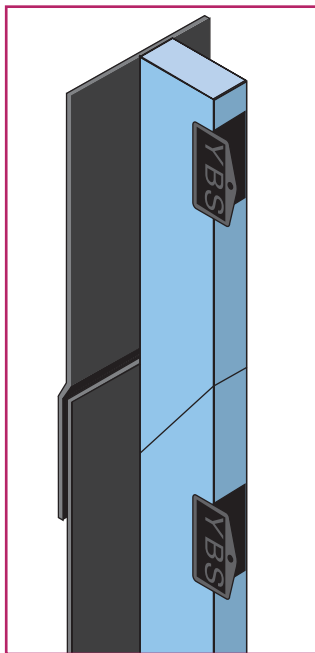

Minimal Waste

If required, lengths of **Therma-Close** can be joined, thus reducing waste. The dpc should be overlapped by 100mm with the insulation being mitred, as shown in the diagram above.

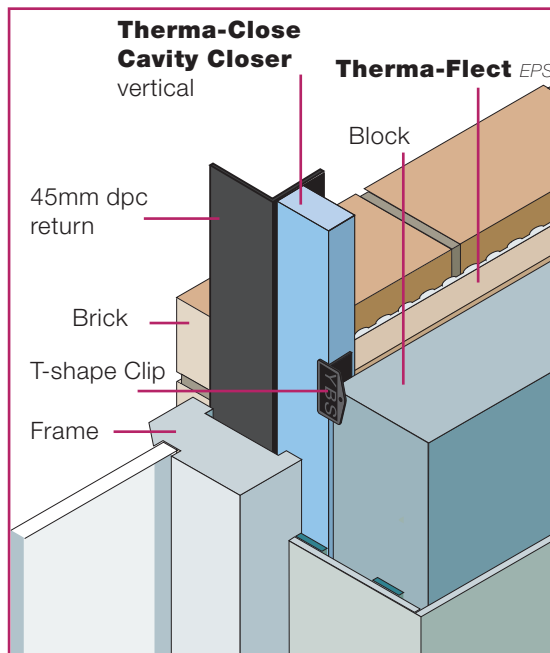

Clip Fixing

The unique feature of **Therma-Close** is the polypropylene clips which aid the cavity closer to be positioned, without the need to slide in ties, which can be time consuming and laborious.

Therma-Close comes with prefixed clips at 300mm centres, which means that the cavity closer can be cut to your requirements and still be located with ease

Therma-Close
can be supplied in
any width to suit
your cavity.

Features

- Waterproofing, Insulating, Self Locating in one fully assembled piece.
- Unique design, incorporates locating clips for quick and economical application.
- Robust, easy to use on-site, can be cut to size and jointed, minimising waste.
- Cavity closer incorporating a D.P.C.
- Eliminates the need for blockwork to close the cavity.
- Thermal conductivity 0.029 W/mK.
- CFC / HCFC Free, therefore kinder to the environment.

PLEASE SPECIFY:

Insulated Cavity

Closers to be:

Therma-Close

Length: 2.5m x

Width: XXXmm

By: YBS Insulation

For technical advice and support please call:

tel: 01909-721662

or fax: 01909-721442

Calculation method for assessing Thermal Bridging at the edges of openings

Example

The diagram below shows a window jamb in a masonry cavity wall, with **Therma-Close** closing the cavity.

Robust details require a cavity closer with a minimum Thermal Resistance of 0.45m²K/W

Calculation of Thermal Resistance Path ('R' value)

This table shows the thermal resistance for each segment of the path ABCD. The thermal resistance for each segment is obtained by dividing the length of the path segment in metres by its thermal conductivity in W/mK

Path Segments	Length (m)	Conductivity (W/mK)	Resistance (m ² K/W)
A-B	0.0275	0.12	0.23
B-C	0.030	0.029	1.034
C-D	0.040	0.770	0.052

Thermal Resistance Path ('R' value) = 1.316m²K/W

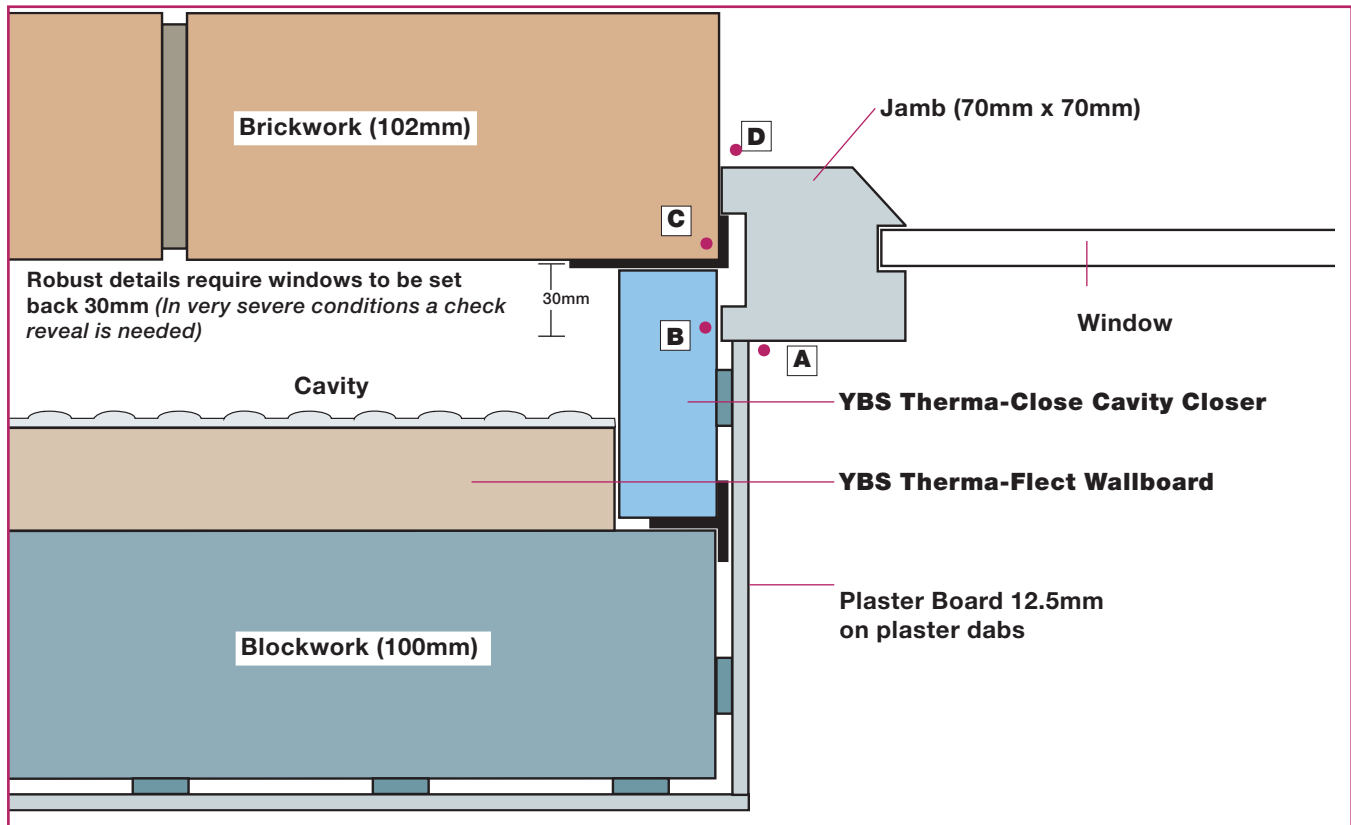

Technical References

Building Regulations 2000 Approved Document L1 + L2.
 BRE publication "Thermal Insulation: Avoiding the risks".
 TSO Publication: Limiting Thermal Bridging and Air Leakage :
 Robust Construction Details for Dwellings and Similar Buildings
 BRE Scotland: Conventions for U Value Calculations



Yorkshire Building Services (WHITWELL) Ltd.
 The Crags Industrial Park, Morven Street, Creswell, Derbyshire S80 4AJ
 Tel: 01909 721662 Fax: 01909 721442
sales@ybsinsulation.com www.ybsinsulation.com